

8.4 Special Right Triangles

Learning Objectives

- Identify and use the ratios involved with isosceles right triangles.
- Identify and use the ratios involved with 30-60-90 triangles.

Review Queue

Find the value of the missing variable(s). Simplify all radicals.

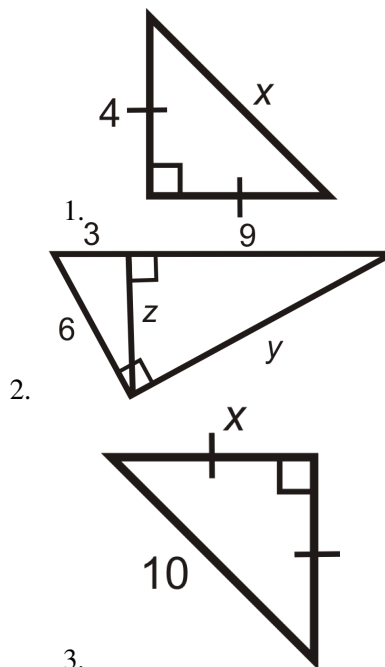

- Do the lengths 6, 6, and $6\sqrt{2}$ make a right triangle?
- Do the lengths 3 , $3\sqrt{3}$, and 6 make a right triangle?

Know What? The Great Giza Pyramid is a pyramid with a square base and four isosceles triangles that meet at a point. It is thought that the original height was 146.5 meters and the base edges were 230 meters.

First, find the length of the edge of the isosceles triangles. Then, determine if the isosceles triangles are also equilateral triangles. Round your answers to the nearest tenth.

You can assume that the height of the pyramid is from the center of the square base and is a vertical line.

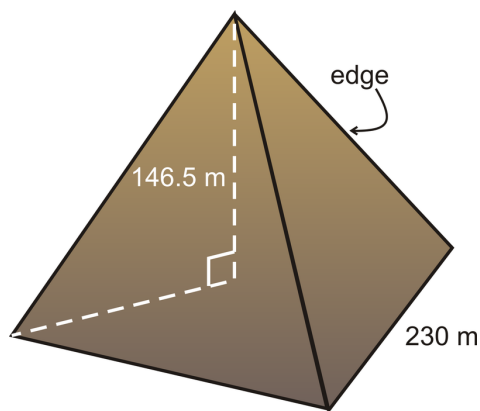

Isosceles Right Triangles

There are two types of special right triangles, based on their angle measures. The first is an isosceles right triangle. Here, the legs are congruent and, by the Base Angles Theorem, the base angles will also be congruent. Therefore, the angle measures will be 90° , 45° , and 45° . You will also hear an isosceles right triangle called a 45-45-90 triangle. Because the three angles are always the same, all isosceles right triangles are similar.

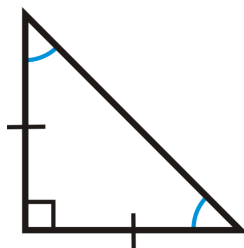

Investigation 8-2: Properties of an Isosceles Right Triangle

Tools Needed: Pencil, paper, compass, ruler, protractor

1. Construct an isosceles right triangle with 2 in legs. Use the SAS construction that you learned in Chapter 4.

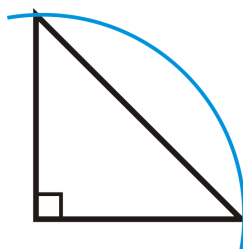

2. Find the measure of the hypotenuse. What is it? Simplify the radical.
3. Now, let's say the legs are of length x and the hypotenuse is h . Use the Pythagorean Theorem to find the hypotenuse. What is it? How is this similar to your answer in #2?

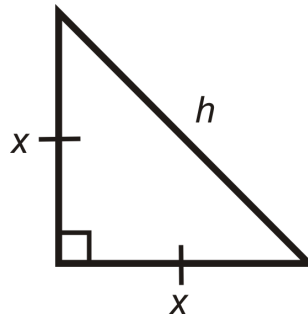

$$x^2 + x^2 = h^2$$

$$2x^2 = h^2$$

$$x\sqrt{2} = h$$

45-45-90 Corollary: If a triangle is an isosceles right triangle, then its sides are in the extended ratio $x : x : x\sqrt{2}$.

Step 3 in the above investigation proves the 45-45-90 Triangle Theorem. So, anytime you have a right triangle with congruent legs or congruent angles, then the sides will always be in the ratio $x : x : x\sqrt{2}$. The hypotenuse is always $x\sqrt{2}$ because that is the longest length. This is a specific case of the Pythagorean Theorem, so it will still work, if for some reason you forget this corollary.

Example 1: Find the length of the missing sides.

a)

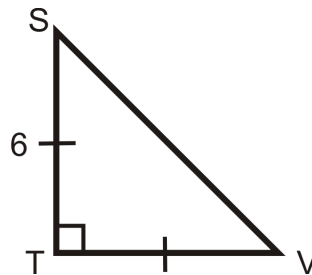

b)

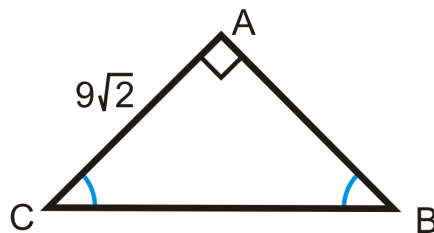

Solution: Use the $x : x : x\sqrt{2}$ ratio.

a) $TV = 6$ because it is equal to ST . So, $SV = 6\sqrt{2}$.

b) $AB = 9\sqrt{2}$ because it is equal to AC . So, $BC = 9\sqrt{2} \cdot \sqrt{2} = 9 \cdot 2 = 18$.

Example 2: Find the length of x .

a)

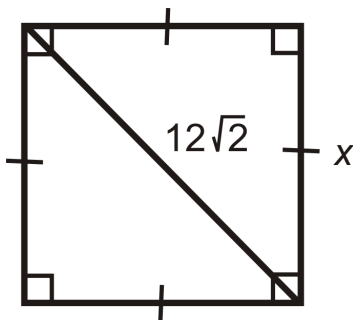

b)

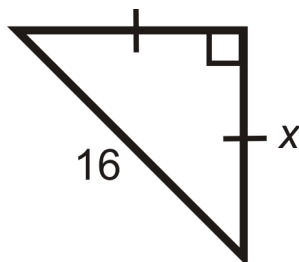

Solution: Again, use the $x : x : x\sqrt{2}$ ratio, but in these two we are given the hypotenuse. We need to solve for x in the ratio.

$$\begin{aligned} \text{a) } 12\sqrt{2} &= x\sqrt{2} \\ 12 &= x \end{aligned}$$

$$\text{b) } x\sqrt{2} = 16$$

$$x = \frac{16}{\sqrt{2}} \cdot \frac{\sqrt{2}}{\sqrt{2}} = \frac{16\sqrt{2}}{2} = 8\sqrt{2}$$

In part b, we *rationalized the denominator*. Whenever there is a radical in the denominator of a fraction, multiply the top and bottom by that radical. This will cancel out the radical from the denominator and reduce the fraction.

30-60-90 Triangles

The second special right triangle is called a 30-60-90 triangle, after the three angles. To construct a 30-60-90 triangle, start with an equilateral triangle.

Investigation 8-3: Properties of a 30-60-90 Triangle

Tools Needed: Pencil, paper, ruler, compass

1. Construct an equilateral triangle with 2 in sides.

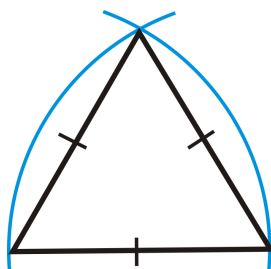

2. Draw or construct the altitude from the top vertex to the base for two congruent triangles.

3. Find the measure of the two angles at the top vertex and the length of the shorter leg.

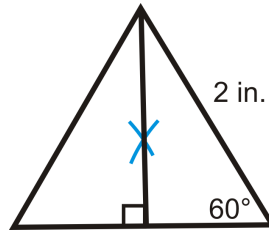

The top angles are each 30° and the shorter leg is 1 in because the altitude of an equilateral triangle is also the angle and perpendicular bisector.

4. Find the length of the longer leg, using the Pythagorean Theorem. Simplify the radical.
5. Now, let's say the shorter leg is length x and the hypotenuse is $2x$. Use the Pythagorean Theorem to find the longer leg. What is it? How is this similar to your answer in #4?

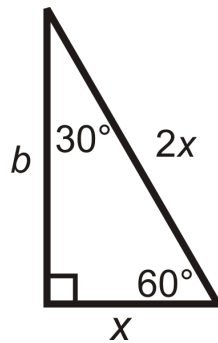

$$x^2 + b^2 = (2x)^2$$

$$x^2 + b^2 = 4x^2$$

$$b^2 = 3x^2$$

$$b = x\sqrt{3}$$

30-60-90 Corollary: If a triangle is a 30-60-90 triangle, then its sides are in the extended ratio $x : x\sqrt{3} : 2x$.

Step 5 in the above investigation proves the 30-60-90 Corollary. The shortest leg is always x , the longest leg is always $x\sqrt{3}$, and the hypotenuse is always $2x$. If you ever forget this corollary, then you can still use the Pythagorean Theorem.

Example 3: Find the length of the missing sides.

a)

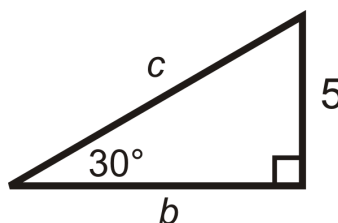

b)

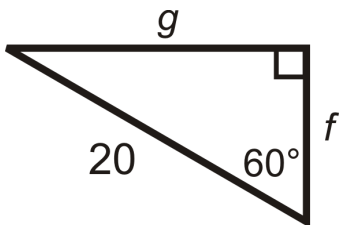

Solution: In part a, we are given the shortest leg and in part b, we are given the hypotenuse.

a) If $x = 5$, then the longer leg, $b = 5\sqrt{3}$, and the hypotenuse, $c = 2(5) = 10$.

b) Now, $2x = 20$, so the shorter leg, $f = 10$, and the longer leg, $g = 10\sqrt{3}$.

Example 4: Find the value of x and y .

a)

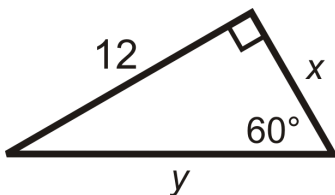

b)

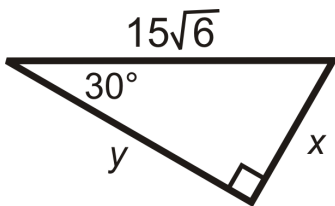

Solution: In part a, we are given the longer leg and in part b, we are given the hypotenuse.

a) $x\sqrt{3} = 12$

$$x = \frac{12}{\sqrt{3}} \cdot \frac{\sqrt{3}}{\sqrt{3}} = \frac{12\sqrt{3}}{3} = 4\sqrt{3}$$

Then, the hypotenuse would be

$$y = 2(4\sqrt{3}) = 8\sqrt{3}$$

b) $2x = 15\sqrt{6}$

$$x = \frac{15\sqrt{6}}{2}$$

The, the longer leg would be

$$y = \left(\frac{15\sqrt{6}}{2}\right) \cdot \sqrt{3} = \frac{15\sqrt{18}}{2} = \frac{45\sqrt{2}}{2}$$

Example 5: Find the measure of x .

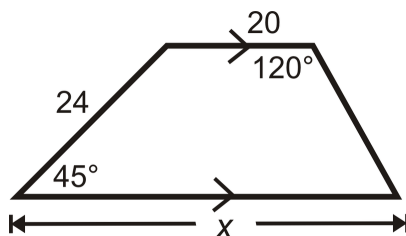

Solution: Think of this trapezoid as a rectangle, between a 45-45-90 triangle and a 30-60-90 triangle.

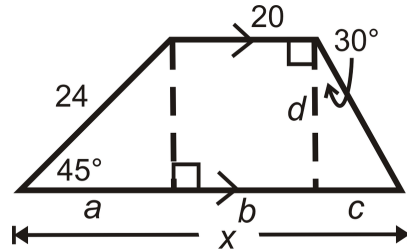

From this picture, $x = a + b + c$. First, find a , which is a leg of an isosceles right triangle.

$$a = \frac{24}{\sqrt{2}} \cdot \frac{\sqrt{2}}{\sqrt{2}} = \frac{24\sqrt{2}}{2} = 12\sqrt{2}$$

$a = d$, so we can use this to find c , which is the shorter leg of a 30-60-90 triangle.

$$c = \frac{12\sqrt{2}}{\sqrt{3}} \cdot \frac{\sqrt{3}}{\sqrt{3}} = \frac{12\sqrt{6}}{3} = 4\sqrt{6}$$

$b = 20$, so $x = 12\sqrt{2} + 20 + 4\sqrt{6}$. Nothing simplifies, so this is how we leave our answer.

Know What? Revisited The line that the vertical height is perpendicular to is the diagonal of the square base. This length (blue) is the same as the hypotenuse of an isosceles right triangle because half of a square is an isosceles right triangle. So, the diagonal is $230\sqrt{2}$. Therefore, the base of the right triangle with 146.5 as the leg is half of $230\sqrt{2}$ or $115\sqrt{2}$. Do the Pythagorean Theorem to find the edge.

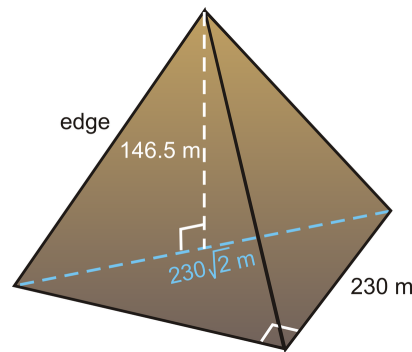

$$edge = \sqrt{(115\sqrt{2})^2 + 146.5^2} \approx 218.9 \text{ m}$$

In order for the sides to be equilateral triangles, this length should be 230 meters. It is not, so the triangles are isosceles.

Review Questions

1. In an isosceles right triangle, if a leg is x , then the hypotenuse is _____.

2. In a 30-60-90 triangle, if the shorter leg is x , then the longer leg is _____ and the hypotenuse is _____.
3. A square has sides of length 15. What is the length of the diagonal?
4. A square's diagonal is 22. What is the length of each side?
5. A rectangle has sides of length 4 and $4\sqrt{3}$. What is the length of the diagonal?
6. A baseball diamond is a square with 90 foot sides. What is the distance from home base to second base? (HINT: It's the length of the diagonal).

For questions 7-18, find the lengths of the missing sides.

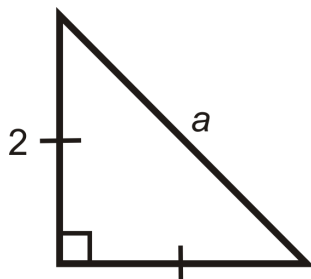

7.

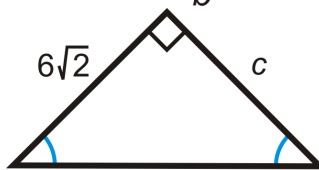

8.

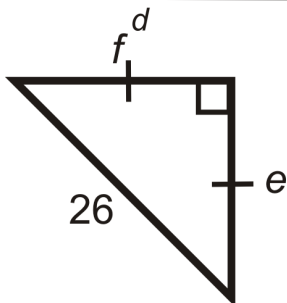

9.

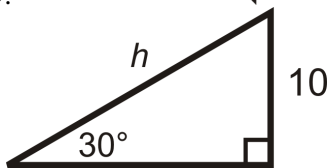

10.

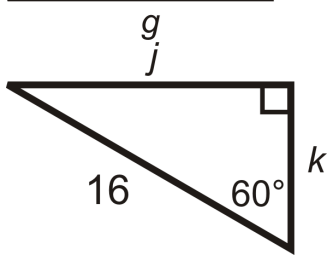

11.

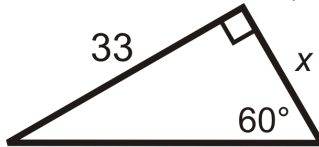

12.

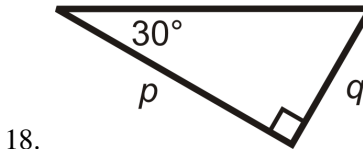
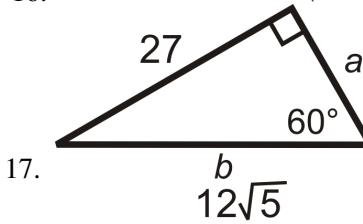
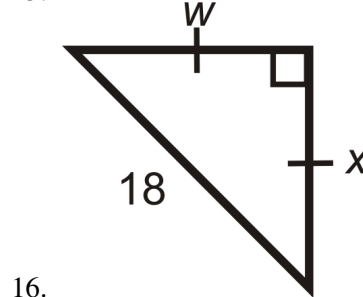
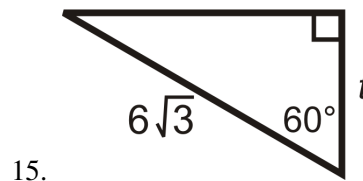
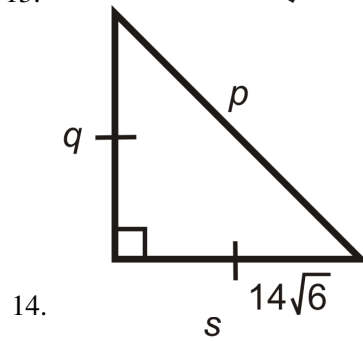
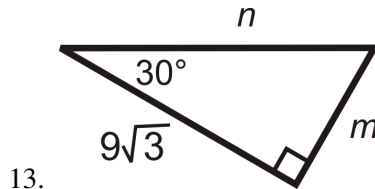

19. Do the lengths $8\sqrt{2}$, $8\sqrt{6}$, and $16\sqrt{2}$ make a special right triangle? If so, which one?
 20. Do the lengths $4\sqrt{3}$, $4\sqrt{6}$ and $8\sqrt{3}$ make a special right triangle? If so, which one?
 21. Find the measure of x .

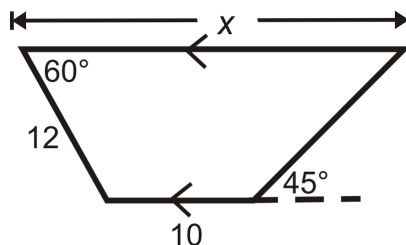

22. Find the measure of y .

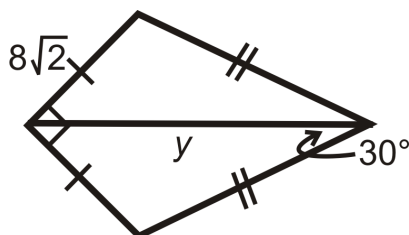

23. What is the ratio of the sides of a rectangle if the diagonal divides the rectangle into two 30-60-90 triangles?
24. What is the length of the sides of a square with diagonal 8 in?

For questions 25-28, it might be helpful to recall #25 from section 8.1.

25. What is the height of an equilateral triangle with sides of length 3 in?
26. What is the area of an equilateral triangle with sides of length 5 ft?
27. A regular hexagon has sides of length 3 in. What is the area of the hexagon? (*Hint: the hexagon is made up of 6 equilateral triangles.*)
28. The area of an equilateral triangle is $36\sqrt{3}$. What is the length of a side?
29. If a road has a grade of 30° , this means that its angle of elevation is 30° . If you travel 1.5 miles on this road, how much elevation have you gained in feet ($5280 \text{ ft} = 1 \text{ mile}$)?
30. Four isosceles triangles are formed when both diagonals are drawn in a square. If the length of each side in the square is s , what are the lengths of the legs of the isosceles triangles?

Review Queue Answers

1. $4^2 + 4^2 = x^2$
 $32 = x^2$
 $x = 4\sqrt{2}$
2. $3^2 + z^2 = 6^2$ $(3\sqrt{3})^2 + 9^2 = y^2$
 $z^2 = 27$ $108 = y^2$
 $z = 3\sqrt{3}$ $y = 6\sqrt{3}$
3. $x^2 + x^2 = 10^2$
 $2x^2 = 100$
 $x^2 = 50$
 $x = 5\sqrt{2}$
4. Yes, $6^2 + 6^2 = (6\sqrt{2})^2 \rightarrow 36 + 36 = 72$
5. Yes, $3^2 + (3\sqrt{3})^2 = 6^2 \rightarrow 9 + 27 = 36$